



Sleek modern appearance
in stainless steel and glass



Heated double glazed
curved front glass for
maximum condensation protection



Excellent and even refrigeration
performance throughout via
unique directed air system

DEALER:

Display Case

REFRIGERATED DISPLAY CASE - ERD SERIES



KTERD.12

KOLDTECH

The Technology of Excellence

Front View

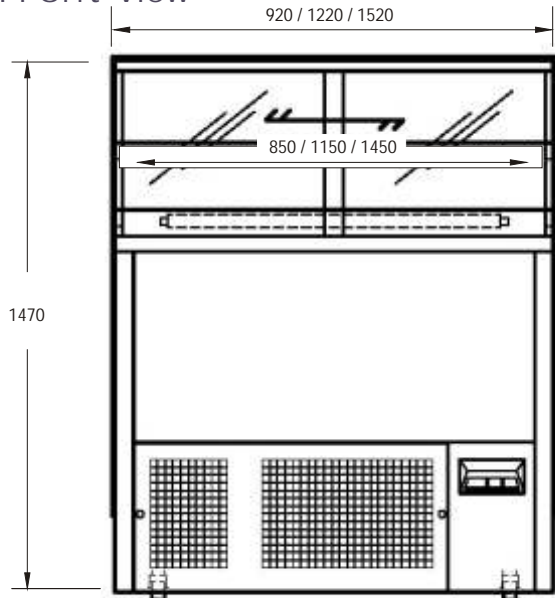

Side View

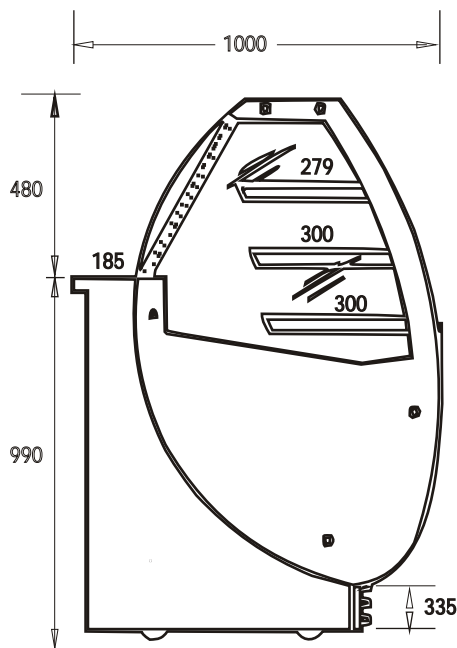

Matching hot units available - ask about our HCD series

ERD-SERIES

curved display case

Performance and operating conditions

ERD series cake displays are designed to hold products at below 5°C. Thermostat adjustable between 2°C & 15°C for products requiring different holding temperatures. The ERD series cake display are rated to operate at ambient temperatures up to 32°C. Glass is guaranteed to remain free of condensation at up to 70% relative humidity.

Standard Features

Refrigeration system

Reliable self contained, bottom mounted refrigeration system using environmentally friendly R134a refrigerant. All ventilation at rear of cabinet. Refrigeration system easily serviceable from removable panel at rear of unit. No drainage connection required.

Controller

Microprocessor controlled with adjustable digital temperature display. Separate power and light switches.

Body & furnishing

Heated double glazed curved front glass to prevent condensation. Double glazed sliding rear doors - angled for easy access. 304 grade stainless steel interior, work shelf, serving shelf and exterior panelling. No drainage connection required. Rigid steel frame for extra strength. Supplied on removable castors

Shelves

4 fixed glass topped shelves, each illuminated with high impact lighting. Top 3 shelves fitted to frames and mounted to front of cabinet for optimum product display. Solid bottom shelf.

Warranty

12 months onsite parts & labour.

Technical Data

KT.ERD - 9

Watts	504
Cooling capacity (Btu) Compressor (Hp)	1910 / 1/2

KT.ERD - 12

Watts	600
Cooling capacity (Btu) Compressor (Hp)	1910 / 1/2

KT.ERD - 15

Watts	1008
Cooling capacity (Btu) / Compressor (Hp)	2729 / 3/4

Continued product improvement is WELBILT Manufacturing Ltd policy. Specifications are subject to change without notice

Manufactured by Welbilt Manufacturing Ltd.
Imported by Tom Stoddart Pty Ltd,
215 Jackson Road Sunnybank Hills Qld 4109
Warranty, Service & dealer enquiries:
(07) 3344 2444 Fax: (07) 3345 6403

