

ELEVATION

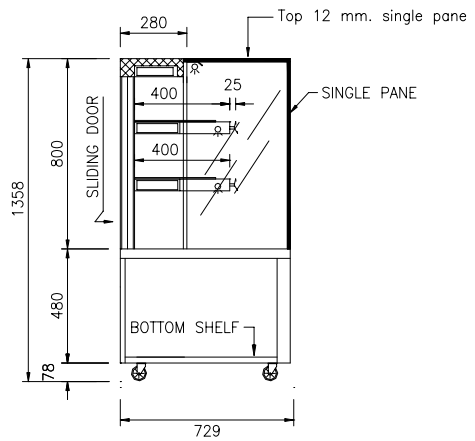

CROSS SECTION

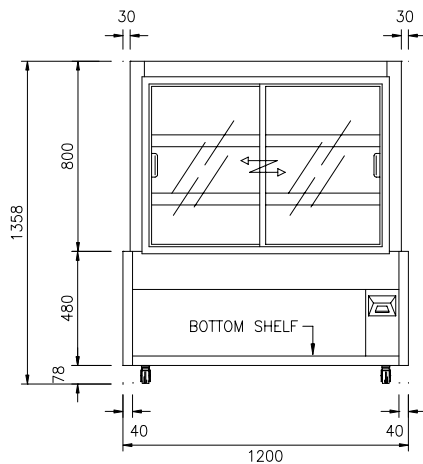

BACK VIEW

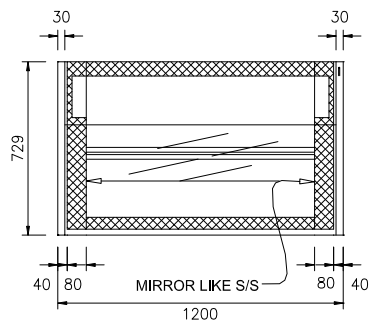

TOP VIEW

TECHNICAL DATA		NRSQCD-12
a)	EXTERNAL DIM. (W x D x H)	1200 x 729 x 1358
b)	GLASS SHELVES (Tier (s))	2
c)	INTERIOR LIGHT (W.) , [Fluo]	30x3
d)	VOLTAGE SUPPLY / AMPERAGE	220 V., 50 Hz., Single phase / 0.68 A
e)	BODY & SIDE PANEL	Lower part : PUR injection : external cover sheet 21 ga.(0.8 mm.) s/s-304, 2-b finishing, or as specified. Internal cover sheet is 22 ga.s/s 304 mirrorlike polished surface
	BOTTOM PANEL	PUR panel : cover sheet is 22 ga.s/s-304 (0.6 mm.)
	SKELETON	Angle steel bar 1-1/2" 6mmt.
	TOP GLASS	Single pane 12 mm.t
	FRONT GLASS (Upper display cabinet constructions)	Single pane
	DOOR STRUCTURE	Single pane, Sliding type
	FURNISHING	Door leave(s) is internally filmed with mirrorlike film faced to front.
f)	OPTION	(a) Selectable furnished materials (b) Colors, (c) Circular adjustable feet

Non-Refrigerated Square Cake Cold Display Units

WELBILT Manufacturing(Thailand)Ltd.	UNLESS OTHERWISE NOTED		PROJECT:	STODDART		P/O NO.
	DESIGN DIMENSIONS ARE IN mm.		PRODUCT:	AS ABOVE SPECIFIED		DATE: 12/03/05
SCALE	NTS.	DWG. NO.	PAGE NO. 1 OF 1	JOB NO.	ITEM:	REVISION:
SA1:	SA2:	MN1:	MN2:	DRAWN:	CHECKED:	APPROVED:
				FM/PD:		AA: